

CODIGO	F. INS. [Kg] MACHO MAX.	F. 1° EXT. [Kg] MACHO MAX.	EXT. [Kg] MACHO MIN. LUEGO DE 30 MANIOBRAS CON MACHO MAXIMO	SEC. CONDUCTOR [MM. ²]	OBS.
11053xx411 (53.411)	≤ 2.0	≤ 1.7	≥ 0.15	0.50 / 1.50	

②

②

②

②

①

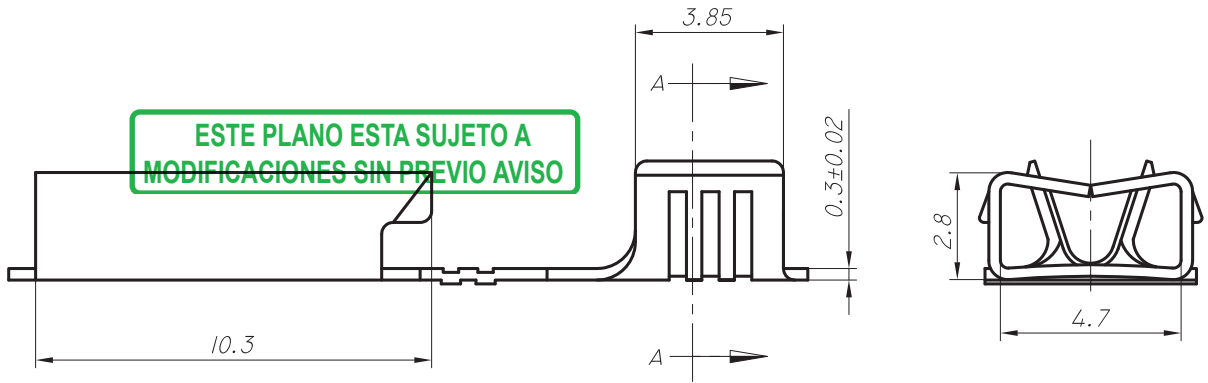

**COPIA
NO CONTROLADA**

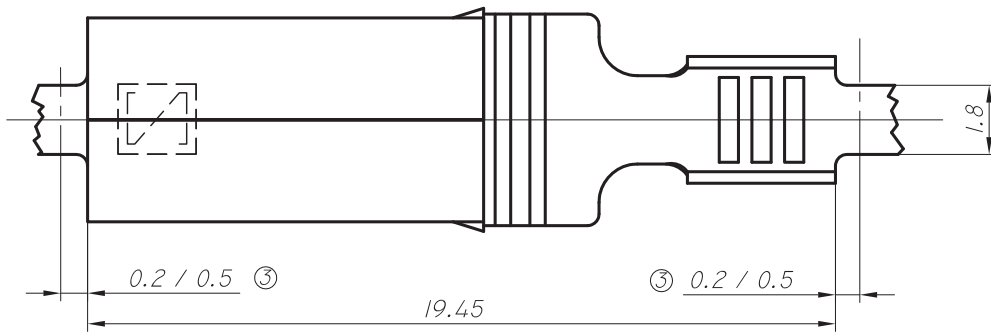

③

CORTE A-A

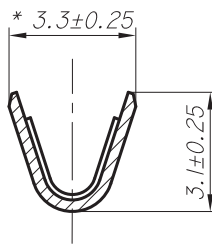

12.01.07	3	COTAS ERAN 0.7 MAX.	L.L.		
03.11.06	2	SE MODIFICAN VALORES DE CARGAS, ERA INS.: 1.20/2.40, 1° EXT.: 1.20/2.40 Y 10° EXT.: 1.20/2.40.	L.L.	O.A.C.	GARCIA
26.07.06	1	SECCION DEL CONDUCTOR ERA 0.35 / 1.0.	L.L.	O.A.C.	GARCIA
FECHA	N°	MODIFICACIONES	DIBUJO	REVISO	APROBO



INDUSTRIAS ZETA S.R.L.

TOLERANCIA NO ACOTADA:

LINEAL: ±0.15

ANGULAR: ± 1° 30'

MATERIAL: LATON	ESCALA: 4 : 1	DIBUJO	REVISO	APROBO
CODIGO MAS: /E = TERMINACION ESTAÑADA /N = TERMINACION NIQUELADA /P = TERMINACION PLATEADA /S = PIEZA SUELTA	HOJA: 2 DE 2	L.L.	O.A.C.	GARCIA
		22.07.05	22.07.05	22.07.05

DENOMINACION: TERMINAL HEMBRA COMPUTACION C/ TAPA

PLANO PARA
CLIENTE N°:

53000